

AyrKing Corporation

Breader/Blender/Sifter

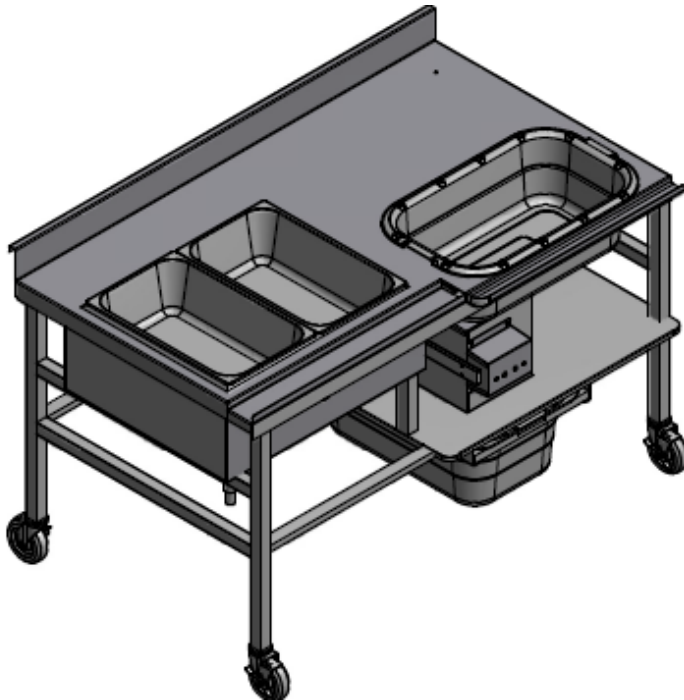

AyrKing offers a breadng workstation and automatic Blender/Sifter machine with integrated ice bath prep area. Rotary brush sifter operates without detrimental vibration or agitation. Spirally configured nylon bristles form an auger to eject unwanted dough balls to a waste container. Ingredients are fully blended as brush tumbles breadng media before it exits through sifter screen. Unique process prevents dough ball grinding, eliminates usual sifting noise, & blends ingredients as it ejects waste.



INCLUDED ACCESSORIES

B101 Red plastic lug plug

B304 White plastic dough ball pan

B302 White plastic breadng lug with hole

B303 White plastic breadng lug no hole (2)

B325 White plastic lug cover (2)

3720149 5" Locking swivel caster w/ square stem

OPTIONAL ACCESSORIES

B619 S/S wire batter basket

ADVANTAGES

Sift and blend 30 lbs (14 kg) of breadng in 60 seconds in each sifter!

Rotary auger brush blends, sifts, and ejects dough balls simultaneously

Blending brush action prevents ingredient segregation, unlike vibrating or agitating systems

Quiet, vibration-free operation creates results, not disturbances

Sixty second timed cycle frees labor and saves energy

Raised s/s lip around sifter opening prevents tabletop spills from contaminating sifted breadng

Fully enclosed sifter with only three internal parts, reduces dust and allows quick and easy cleaning

Direct drive, steel geared motor & solid stainless steel fabrication provide lasting performance

Integrated, insulated ice bath well holds two full size pans (pans not included)

MODEL

BBS-U-L6035RH RIGHT HAND SIFTER 60"L by 35"W by 36"H table on casters with ice bath well

AyrKing Corporation
2013 Cobalt Drive
Louisville, KY 40299-2417

Telephone 502-266-6270
Facsimile 502-266-6274
www.ayrking.com

AyrKing Corporation

Breader/Blender/Sifter

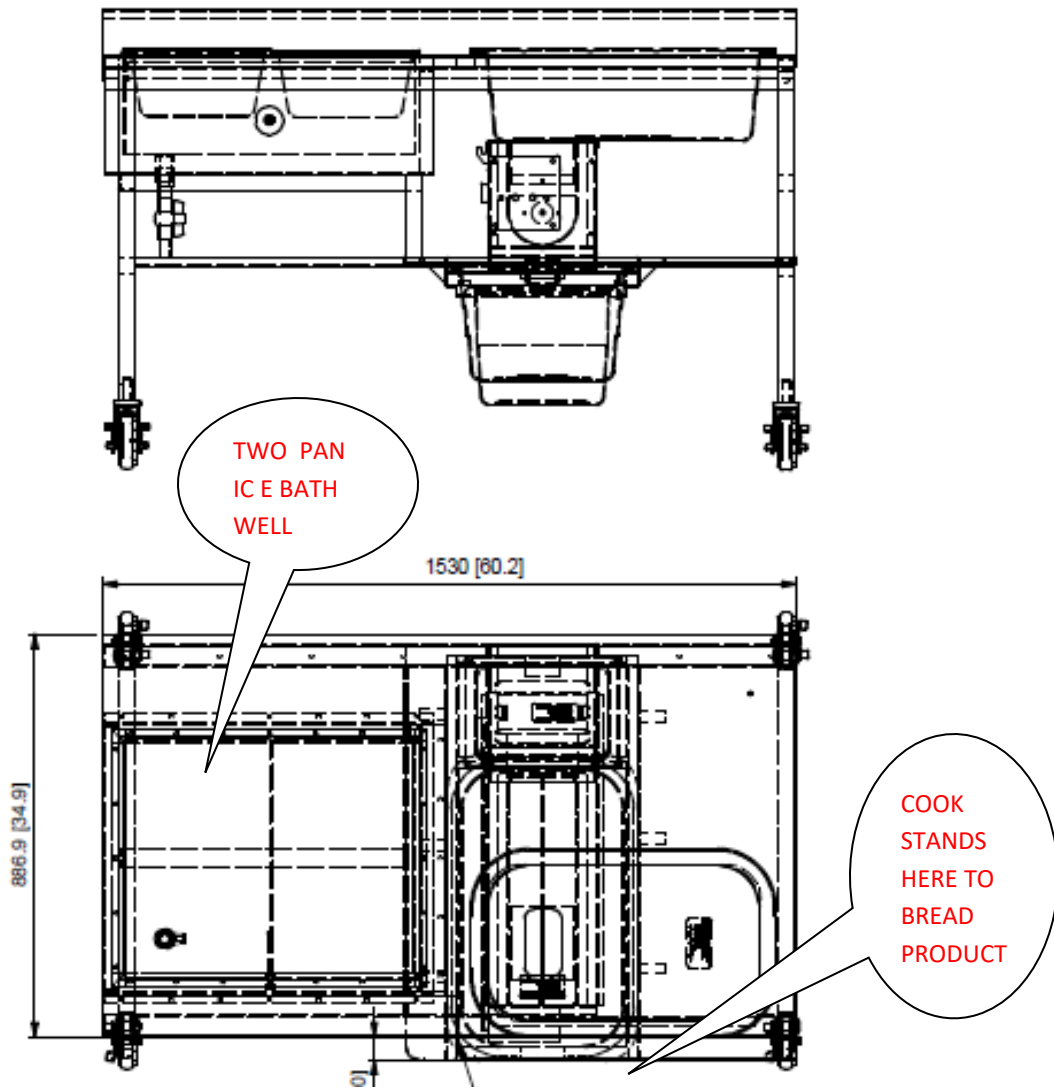

CRATED MEASUREMENTS

MODEL
BBS-U-L6035RH

| <u>LENGTH</u> | <u>WIDTH</u> | <u>HEIGHT</u> | <u>WEIGHT</u> |
|---------------|--------------|---------------|----------------|
| 66" (1676mm) | 40" (1016mm) | 48" (1219mm) | 315 lb (143kg) |

UNCRATED
230 lb (105kg)

ELECTRICAL

Timed control board automatically senses voltage & operates at either:
 115V, 50/60Hz, 1 phase, 1.6 AMP, 184W per sifter
 230V, 50/60Hz, 1 phase, 0.9 AMP, 207W per sifter
 Includes universal male three prong, recessed AC receptacle (IEC 320 C13) mating to an 8 foot (2438mm) cord with NEMA 5-15P male three prong plug

WARRANTY

One Year Parts
 Ninety Days Labor
 No Travel Time

Specifications subject to change without notice. Version 02/17

AyrKing Corporation
 2013 Cobalt Drive
 Louisville, KY 40299-2417

Telephone 502-266-6270
 Facsimile 502-266-6274
www.ayrking.com